

# HANDBOOK FOR INVENTORYING DOWNED WOODY MATERIAL

James K. Brown

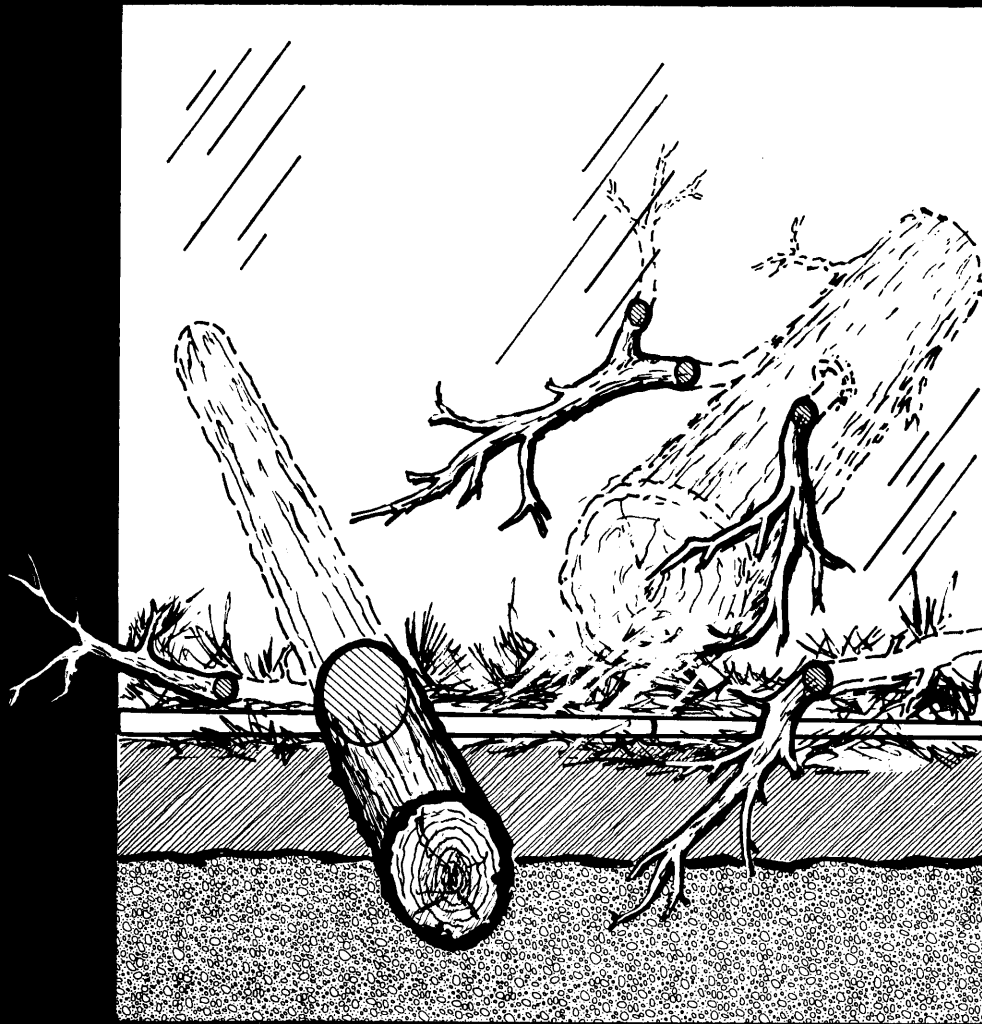

USDA Forest Service General Technical Report INT-16, 1974  
INTERMOUNTAIN FOREST & RANGE  
EXPERIMENT STATION  
Ogden, Utah 84401

This file was created by scanning the printed publication.  
Errors identified by the software have been corrected;  
however, some errors may remain.

USDA Forest Service  
General Technical Report INT-16  
September 1974

# **HANDBOOK FOR INVENTORYING DOWNED WOODY MATERIAL**

**James K. Brown**

INTERMOUNTAIN FOREST AND RANGE EXPERIMENT STATION  
Forest Service  
U.S. Department of Agriculture  
Ogden, Utah 84401  
Roger R. Bay, Director

## **THE AUTHOR**

JAMES K. BROWN received his bachelor's degree from the University of Minnesota in 1960, his master's from Yale University in 1961, and his Ph. D. from the University of Michigan in 1968, all in forestry. From 1961 to 1965 he did research on field measurement of fuel properties and fire-danger rating systems while with the Lake States Forest Experiment Station. In 1965 he transferred to the Northern Forest Fire Laboratory, Missoula, Montana, where he is responsible for research on the physical properties and inventory of fuel.

# CONTENTS

	Page
INTRODUCTION . . . . .	1
NUMBER AND SIZE OF SAMPLING PLANES . . . . .	3
FIELD PROCEDURES . . . . .	4
Locating Sample Points . . . . .	4
Sample Point Procedures . . . . .	4
Tally Rules . . . . .	9
Heavy Slash Options . . . . .	11
Utilization Options . . . . .	12
Field Equipment . . . . .	12
CALCULATIONS . . . . .	13
FURTHER APPLICATIONS . . . . .	19
LITERATURE CITED . . . . .	20
APPENDIX I . . . . .	21
Sampling Intensities . . . . .	21
Number and Size of Sampling Planes . . . . .	21
Sampling Precision for Depth Measurements . . . . .	22
APPENDIX II . . . . .	23
Specific Gravities of Sound Material . . . . .	23
APPENDIX III . . . . .	24
Calculating Needle Quantities . . . . .	24

## **ABSTRACT**

To facilitate debris management, procedures for inventorying downed woody material are presented. Instructions show how to estimate weights and volumes of downed woody material, fuel depth, and duff depth. Using the planar intersect technique, downed material is inventoried by 0- to 0.25-inch, 0.25- to 1-inch, and 1- to 3-inch diameter classes; and by 1-inch classes for sound and rotten pieces over 3 inches. The method is rapid and easy to use and can be applied to naturally fallen debris and to slash. The method involves counting downed woody pieces that intersect vertical sampling planes and measuring the diameters of pieces larger than 3 inches in diameter. The piece counts and diameters permit calculation of tons per acre.

OXFORD: 431

**KEYWORDS:** fire causes (forest), fuel inventory, forest fuels, debris, planar intersect method, sampling methods.

# INTRODUCTION

This Handbook tells how to inventory weights, volumes, and depths of downed woody material. Downed woody material is the dead twigs, branches, stems, and boles of trees and brush that have fallen and lie on or above the ground. This material is usually called slash or logging debris if man creates it by cutting; it is called fuel, natural debris, or detritus if it accumulates without cutting.

Inventorying downed woody material can help land managers practice fuel management, plan for prescribed fire, and estimate utilization potential. For example, undesirable fuel hazards can be identified and plans made for hazard reduction. Fire behavior in wilderness areas can be predicted to aid in implementing let-burn fire policies. The volume of downed fiber can be estimated to plan for sales, removal, and utilization. Managers can communicate in exact terms about their debris problems.

The inventory can be done to provide all or any part of the following information:

1. Weights and volumes per acre of downed woody material for
  - a. Diameter size classes of 0 to 0.25, 0.25 to 1, and 1 to 3 inches; and
  - b. Diameters of 3 inches and larger for sound and rotten conditions.
2. Average diameter of debris larger than 3 inches.
3. Depth of fuel and forest floor duff.

This Handbook applies most accurately in the western United States because it contains average particle diameters for western conifers; however, the procedures are appropriate for forests everywhere. The inventory procedures are rapid and easy to

use. For average amounts of downed debris, about 5 to 6 minutes per sample point are required for the measurements. More time is usually spent in traveling and locating sample points than in making the measurements. If only downed woody material is inventoried, a two-man crew can complete 20 to 40 plots a day, depending on how much debris is present.

The inventory of volumes and weights is based on the planar intersect technique (Brown 1971; Brown and Roussopoulos 1974), which has the same theoretical basis as the line intersect technique (Van Wagner 1968). The planar intersect technique involves counting intersections of woody pieces with vertical sampling planes that resemble guillotines dropped through the downed debris. Volume is estimated; then weight is calculated from volume by applying estimates of specific gravity of woody material. The planar intersect technique is nondestructive and avoids the time-consuming, costly, and often impractical task of collecting and weighing large quantities of forest debris.

Woody pieces less than 3 inches in diameter are tallied by size classes. Pieces 3 inches and larger are recorded by their diameters. Size classes of 0 to 0.25, 0.25 to 1, and 1 to 3 inches were chosen for tallying intersections because:

1. The class intervals provide the most resolution for fine fuels and are small enough to permit precise estimates of volume.
2. They correspond, in increasing size, to 1-, 10-, and 100-hour average moisture timelag classes for many woody materials (Fosberg 1970). [These are standard moisture timelags used in the National Fire-Danger Rating System (Deeming and others 1972).]

Inventory chosen areas as follows:

1. Decide on length of sampling planes and number of sample points.
2. Complete the fieldwork.
3. Calculate weight or volume, size, and depth of debris.



# NUMBER AND SIZE OF SAMPLING PLANES

Choose sampling plane lengths from the following tabulation:

<i>Downed material</i>	<i>Diameter of debris</i>		
	<i>0-1 in</i>	<i>1-3 in</i>	<i>&gt;3 in</i>
	<i>Sampling plane (ft)</i>		
Nonslash (naturally fallen material)	6	10-12	35-50
Discontinuous light slash	6	10-12	35-50
Continuous heavy slash	3	6	15-25

For any area where estimates are desired, 15 to 20 sample points should be located using the sampling plane lengths shown in the tabulation. This sampling intensity will often yield estimates having standard errors within 20 percent of the mean estimates. Areas larger than approximately 50 acres that contain a high diversity in amount and distribution of downed material should be sampled with more than 20 points. If material larger than 3 inches in diameter is scanty or unevenly distributed, the longer sampling planes in the tabulation should be used.

The amount and distribution of downed woody material vary greatly among and within stands. Thus, these sampling recommendations should be considered approximate because a greater or fewer number of plots may be required to furnish adequate precision for any given area. Sampling intensities are discussed further in Appendix I.

# FIELD PROCEDURES

## Locating Sample Points

Locate plots systematically; two methods are:

1. Locate plots at a fixed interval along transects that lace regularly across a sample area (uniform sampling grid). For example, on a sample area, mark off parallel transects that are 5 to 10 chains apart. Then along the transects locate plots at 2- to 5-chain intervals.

2. Locate plots at a fixed interval along a transect that runs diagonally through the sample area. To minimize bias, have the transect cross obvious changes in fuels. Before entering the sample area, determine a transect azimuth and distance between plots.

## Sample Point Procedures

Step 1:        *Mark the sampling point* with a chaining pin (No. 9 wire or similar item). Avoid disturbing material around the point. Accurate estimates require measurements of undisturbed material. If standing tree measurements (d.b.h. and height) are a part of the inventory, measure downed material first.

Step 2:        *Determine direction of sampling plane* by tossing a die to indicate one of six 30° angles between 0° and 150° (fig. 1). The 0° heading is the transect direction. Turn a fixed direction, such as clockwise, to position the sampling plane. As an alternative for indicating direction of the sampling plane, use the position of the second hand on a watch at a given instant. To avoid bias in placement of the sampling plane, do not look at the fuel or ground while turning the interval.

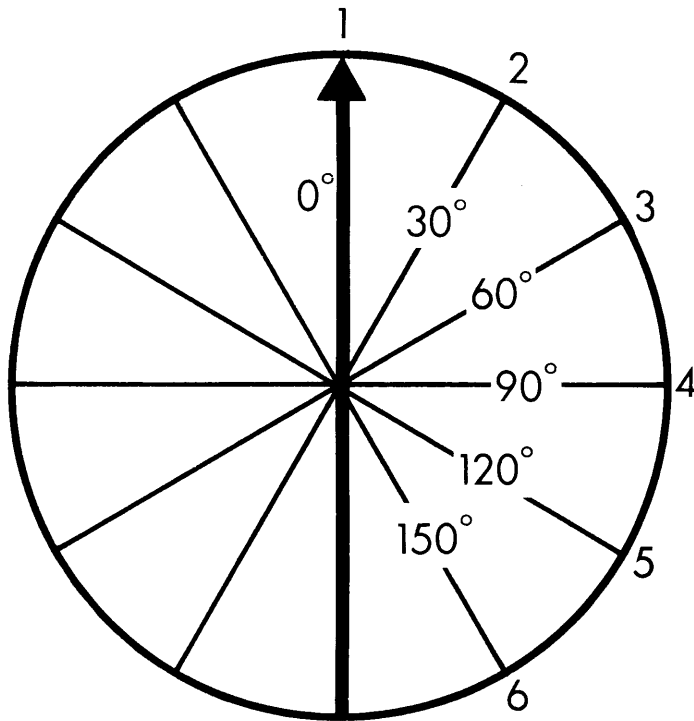

Figure 1.--Locating sampling plane by using die to pick one of six directions.

Step 3: Denote position of the sampling plane by running a tape or string out from the sampling point *parallel to the ground* in the direction determined in Step 2 (fig. 2). Extend the tape to the length of the longest sampling plane. A fiberglass rod or 1/2-inch aluminum tube placed along the string beginning at the sampling point facilitates counting pieces less than 1 inch in diameter. The rod should be 6 feet long, the length of sampling plane for small particles. The tape and rod fix the position of vertical sampling planes.

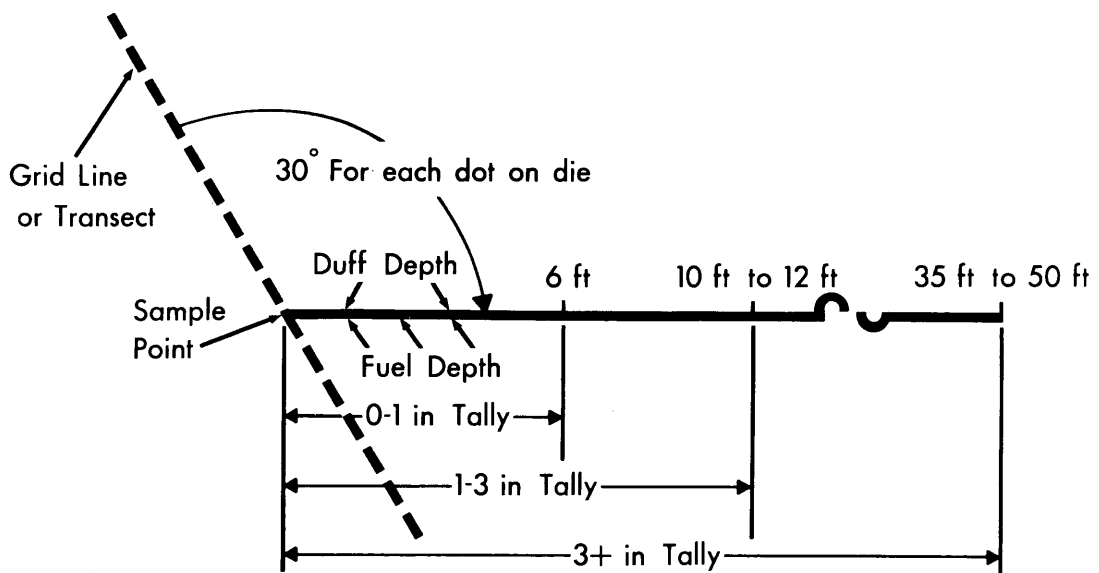

Figure 2.--Top view of sampling plane and location of fuel depth measurements.

Step 4:      *Measure or estimate slope* by sighting along the sampling plane from the sample point using an Abney level or similar device. Ample precision is the nearest 10 percent, which can be coded using one digit (10 percent = 1, 90 percent = 9, etc.).

Step 5:      *Tally the number of particles* that intersect the sampling plane by the following size classes:

0 to 0.24 inch (0 to 0.6 cm)

0.25 to 0.99 inch (0.6 to 2.5 cm)

1.0 to 2.99 inches (2.5 to 7.6 cm)

The intersections can be counted one size class at a time or "dot tallied," which takes slightly longer than counting (see sample data form, page 14).

The actual diameter of the particle at the point of intersection determines its size class. A go-no-go gage with openings 0.25 inch, 1 inch, and 3 inches works well for separating borderline particles into size classes and for training the eye to recognize size classes (fig. 3).

The vertical plane is a plot. Consequently, in counting particle intersections, it is very important to visualize the plane passing through one edge of the plot rod and terminating along an imaginary fixed line on the ground. *Once visualized on the ground, the position of the line should not be changed while counting particles* (fig. 4). See tally rules for qualifying particles.



*Figure 3.--Diameter of the intersected twig is checked with a go-no-go gage. The plot rod marks the sampling plane.*

Figure 4.--The sampling plane is exactly defined by one edge of the plot rod.

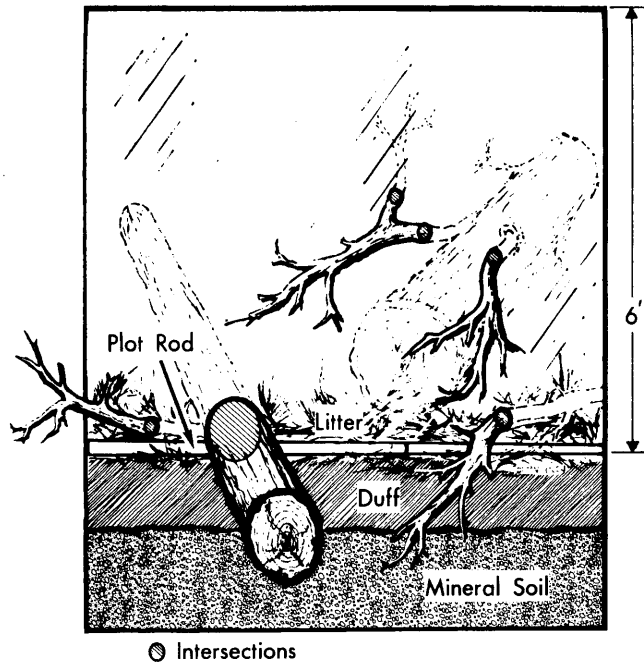

Step 6: Take three measurements of dead fuel depth. Record depth as the vertical distance from the bottom of the litter layer to the highest intersected dead particle for each of three adjacent 1-foot-wide vertical partitions of the sampling plane (fig. 5). Litter is the surface layer of the forest floor and consists of freshly fallen leaves, needles, twigs, bark, and fruits. Begin the vertical partitions at the sample point. Record to the nearest whole inch.

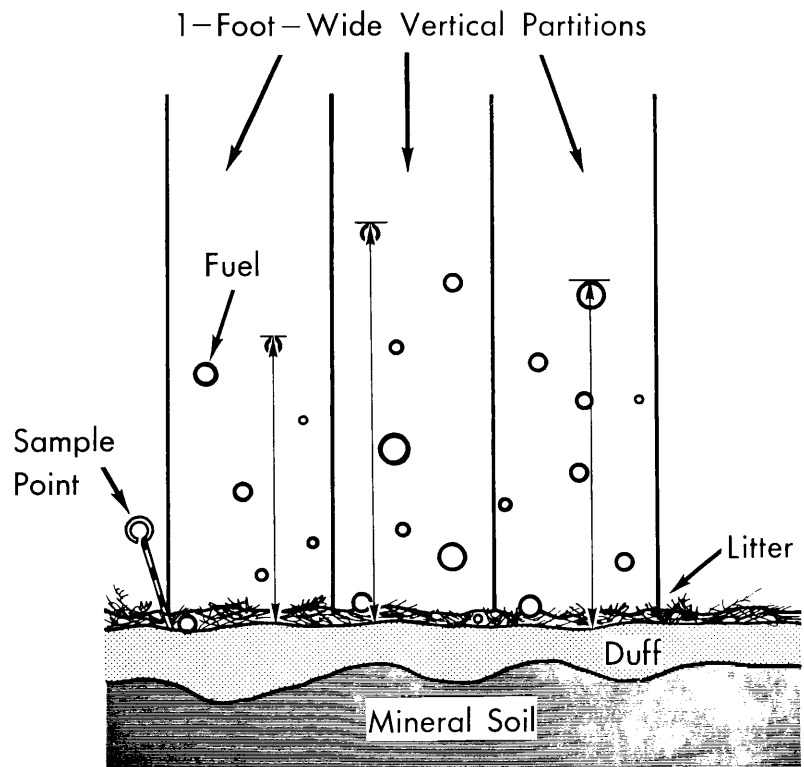

Figure 5.--Cross section of a fuel bed. Depth is measured along the arrows in each 1-foot-wide partition.

Depth should be measured from only those particles included in the inventory for loading. For example, particles acceptable for measurement by the planar intersect technique are also acceptable for determining depth. If other techniques are used to estimate weight per acre of grass and forbs, this vegetation would also qualify for determining depth.

Step 7: Measure vertical depth of duff to the nearest 0.1 inch using a ruler along the sampling plane at two points: (1) 1 foot from the plot center; and (2) a fixed distance of 3 to 5 feet from the first measurement.

Duff is the fermentation and humus layers of the forest floor. It does not include the freshly cast material in the litter layer. The top of the duff is where needles, leaves, and other castoff vegetative material have noticeably begun to decompose. Individual particles usually will be bound by fungal mycelium. When moss is present, the top of the duff is just below the green portion of the moss. The bottom of the duff is mineral soil.

Carefully expose a profile of the forest floor for the measurement. A knife or hatchet helps but is not essential. Avoid compacting or loosening the duff where the depth is measured.

When stumps, logs, and trees occur at the point of measurement, offset 1 foot perpendicular to the right side of the sampling plane. Measure through rotten logs whose central axis is in the duff layer (fig. 6).

Yes= center of log is in duff layer or below.

No= center of log is above duff layer.

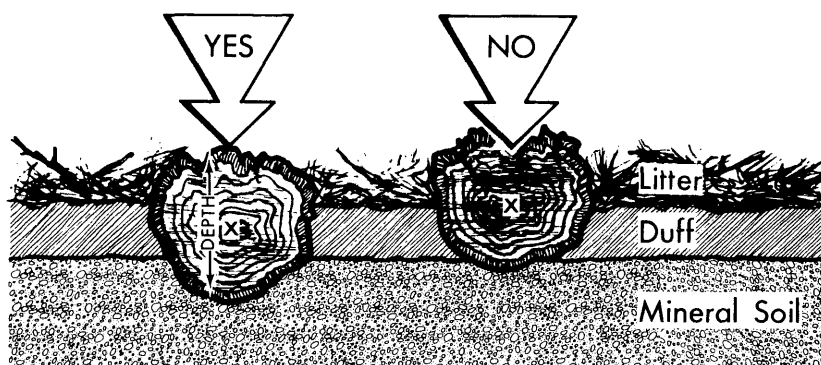

x = center of log

Figure 6.--Duff depth is measured through a rotten log when its central axis lies in or below the duff.

Step 8: Measure or estimate the diameters of all pieces 3 inches in diameter and larger that intersect the sampling plane. Measure the diameters at the point of intersection to the nearest whole inch.

Record diameters separately for rotten and nonrotten pieces. Consider pieces rotten when the piece at the intersection is obviously punky or can be easily kicked apart.

A ruler laid perpendicularly across a large piece of fuel works satisfactorily for measuring diameter. Be sure to avoid parallax in reading the

ruler. Calipers also work well for measuring diameter. A diameter tape, however, is unsatisfactory for pieces in contact with the ground.

Use as many consecutive lines on the data form (see page 14) as necessary to record diameters.

Step 9: For the entire sample area, record the predominate species of the 0- to 1-inch-diameter branchwood. An average diameter for the 0- to 0.25-inch, and 0.25- to 1-inch size classes will be selected from this information. If several species comprise the downed debris, estimate the proportion of the two or three most common species. Base this estimate on a general impression of what exists on the sample area and record as percentages of total 0- to 1-inch branchwood. Or, for a slight reduction in accuracy, omit this step and in the calculations use an average diameter for a composite of species (page 16).

#### TALLY RULES

The following rules apply to downed woody pieces of all diameters:

1. Particles qualifying for tally include *downed, dead* woody material (twigs, stems, branches, and bolewood) from trees and shrubs. Dead branches attached to boles of standing trees are omitted because they are not downed vegetation. Consider a particle downed when it has fallen to the ground or is severed from its original source of growth. Cones, bark flakes, needles, leaves, grass, and forbs are not counted. *Dead woody stems and branches still attached to standing brush and trees are not counted.*

2. Twigs or branches lying in the litter layer and above are counted. However, they are not counted when the intersection between the central axis of the particle and the sampling plane lies in the duff (forest floor below the litter) (fig. 7).

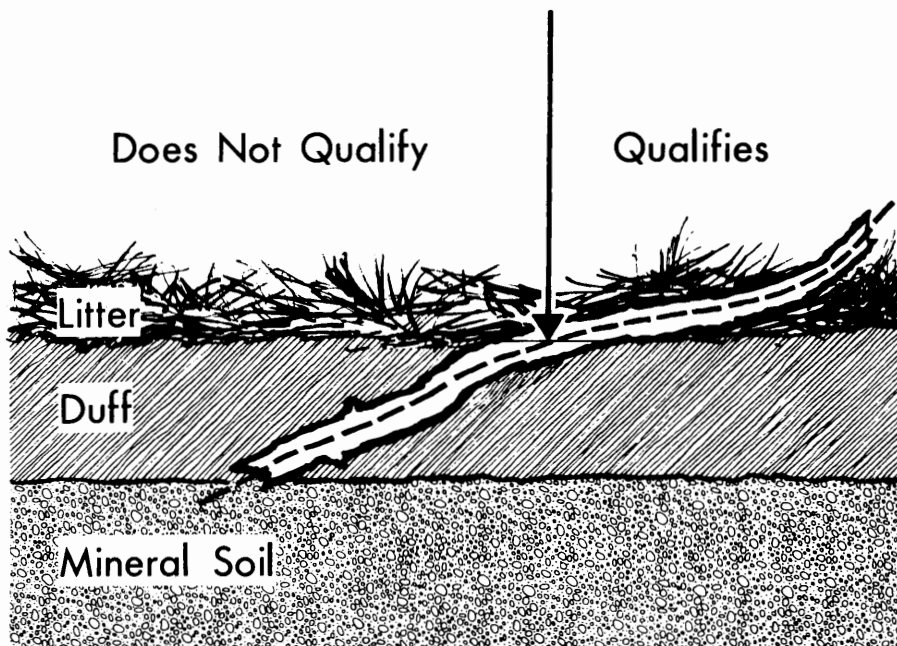

Figure 7.--Regardless of size, pieces are tallied only when intersection lies in and above the litter (right of arrow).

3. If the sampling plane intersects the end of a piece, tally only if the central axis is crossed (fig. 8). If the plane exactly intersects the central axis, tally every other such piece.

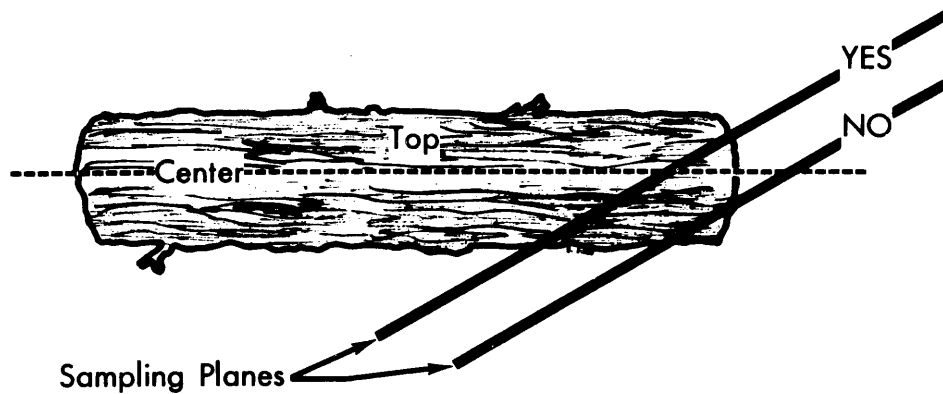

Figure 8.--An intersection at the end of a branch or log must include the central axis to be tallied.

4. Don't tally any particle having a central axis that coincides perfectly with the sampling plane. (This should rarely happen.)

5. If the sampling plane intersects a curved piece more than once, tally each intersection (fig. 9).

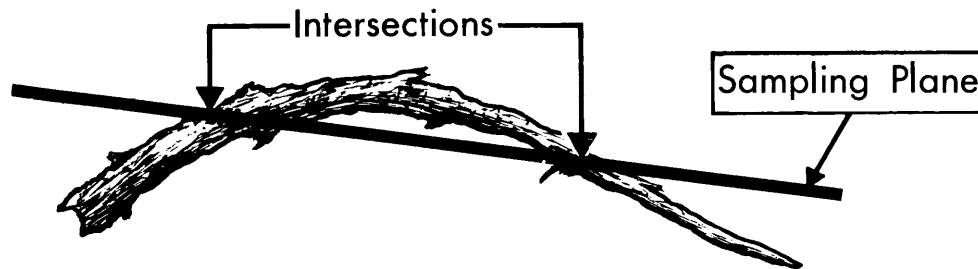

Figure 9.--Count both intersections for a curved piece.

6. Tally wood slivers and chunks left after logging. Visually mold these pieces into cylinders for determining size class or recording diameters.

7. Tally uprooted stumps and roots not encased in dirt. For tallying, consider uprooted stumps as tree boles or individual roots, depending on where the sampling planes intersect the stumps. Do not tally undisturbed stumps.

8. For rotten logs that have fallen apart, visually construct a cylinder containing the rotten material and estimate its diameter. The cylinder will probably be smaller in diameter than the original log.

9. Be sure to look up from the ground when sampling because downed material can be tallied up to any height. A practical upper cutoff is about 6 feet. However, in deep slash it may be necessary to tally above 6 feet.



When standing trees are inventoried along with downed material, it is necessary to fix a limit above the ground for sampling downed material. An upper limit helps define a downed tree so that inventory of standing and downed materials will not overlap.<sup>1/</sup>

#### HEAVY SLASH OPTIONS

1. A yardstick attached to a Jacob's staff is useful for marking the sampling plane and speeds the counting of small particles (fig. 10). Erect the Jacob's staff at the sample point. Aline the yardstick with the direction of the sample plane and level it using an attached bubble level.

*Figure 10.--A yardstick or meter stick attached to a Jacob's staff defines the sampling plane in heavy slash.*

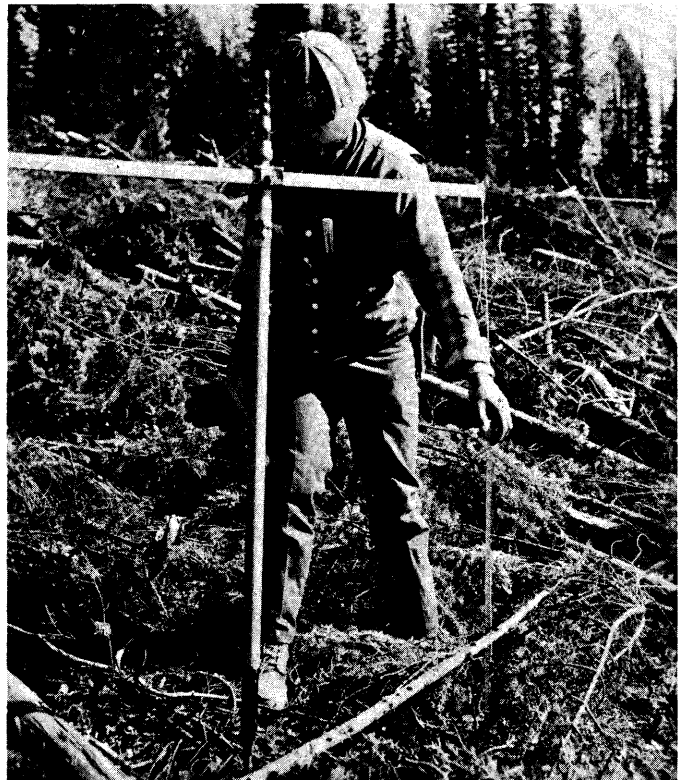

2. In areas with considerable slash, sampling efficiency is improved by ocularly estimating the number of 0- to 0.25-inch intersections and actually counting the number of intersections at a subsample of points. The ocular estimates are adjusted using the ratio of ocular estimates-to-actual counts. This method, incorporating 3P sampling, is described in detail by Beaufait and others (1974).

---

<sup>1/</sup>In the USDA Forest Service Northern Region, a rule has been established that a stem is "downed" and thus qualifies for tallying when the intersection of the sampling plane and central axis is 6 feet or less from the ground. If the midpoint of the bole is more than 6 feet above ground for trees encountered in fixed and variable radius plots, they are inventoried as "standing."

3. For each sampling plane, estimate the proportion of 0- to 1-inch-diameter branchwood to the nearest 10 percent for the three most common species.

*UTILIZATION OPTIONS*

For pieces over 3 inches in diameter, the following additional measurements can be useful for describing utilization potential:

1. Species
2. Length of piece
3. Diameter at large end
4. Degree of checking, rot, and other defects that apply to the entire piece.

## Field Equipment

<i>Item</i>	<i>Use</i>
1. Hand compass	Transect and plot layout.
2. Gaging die	Random orientation of sampling planes.
3. 50-foot tape or string and one chaining pin	Delineate the sampling planes.
4. Plot rod	Delineate sampling planes and if calibrated, measure fuel depth.
5. Go-No-Go gage (fig. 11)	Determine size class of borderline particles.
6. 1-foot ruler or steel pocket tape	Measure duff depth and diameters of pieces over 3 inches. Fuel depth could be measured with steel pocket tape.
7. Hypsometer with percent scale	Slope measurement.
8. Sample forms	Record data.
9. For slash: Jacob's staff with attached yard or meter stick and level	Delineate sampling plane for counting small particles.

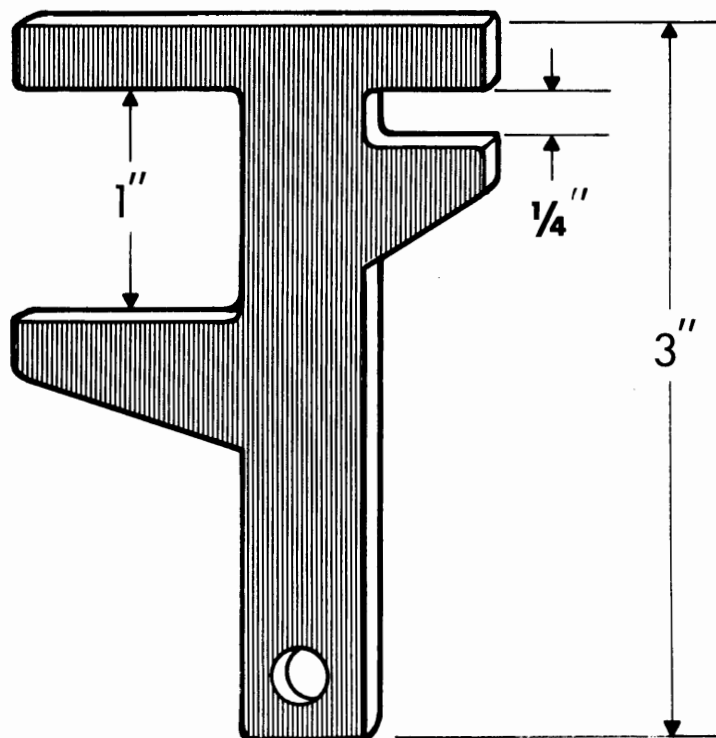

*Figure 11.--A Go-No-Go gage can be cut from 1/16 or 1/8-inch sheet aluminum. Cut the notches slightly tight and file smooth to final dimensions.*

# CALCULATIONS

The calculations can be readily processed by computer<sup>2/</sup> and are also easy using a desk calculator. Sample calculations are shown in figures 12 and 13. For a given stand or sample area, fill in the computation summary sheet as follows:

1. Calculate the average slope correction factor (c) using slope correction factors for each sampling plane. Look up the correction factors in table 1 or compute them by:

$$c = \sqrt{1 + \left(\frac{\text{Percent slope}}{100}\right)^2}$$

No slope correction is needed for samples taken using the Jacob's staff.

Table 1.--*Slope correction factors for converting weight/acre on a slope basis to a horizontal basis*

Slope	Correction factor	Slope	Correction factor
<i>Percent</i>	<i>c</i>	<i>Percent</i>	<i>c</i>
0	1.00	60	1.17
10	1.00	70	1.22
20	1.02	80	1.28
30	1.04	90	1.35
40	1.08	100	1.41
50	1.12	110	1.49

<sup>2/</sup> Card punching instructions and a FORTRAN program for computing the inventory results are available upon request from the Northern Forest Fire Laboratory, Drawer G, Missoula, Montana 59801.



**DOWNED WOODY MATERIAL COMPUTATION SUMMARY**

FOREST: \_\_\_\_\_ COMPARTMENT: \_\_\_\_\_ STAND: \_\_\_\_\_

Formulas to compute tons/acre:

(A) 0- to 3-inch material:  $= \frac{11.64 \times n \times d^2 \times s \times a \times c}{N\%}$

(B) 3+-inch material :  $= \frac{11.64 \times \Sigma d^2 \times s \times a \times c}{N\%}$

Size class	Constant	n	d <sup>2</sup>	s	a	c	N%	Tons/acre	
0 - .25	<u>11.64</u>	<u>32</u>	<u>.0151</u>	<u>.48</u>	<u>1.13</u>	<u>1.08</u>	<u>12</u>	<u>.275</u>	I
.25 - 1	<u>11.64</u>	<u>11</u>	<u>.289</u>	<u>.48</u>	<u>1.13</u>	<u>1.08</u>	<u>12</u>	<u>1.81</u>	II
1 - 3	<u>11.64</u>	<u>3</u>	<u>2.76</u>	<u>.40</u>	<u>1.13</u>	<u>1.08</u>	<u>20</u>	<u>2.35</u>	III
		<u>Ed<sup>2</sup> for 3+</u>							
3+ Sound	<u>11.64</u>	<u>317</u>		<u>.40</u>	<u>1.0</u>	<u>1.08</u>	<u>70</u>	<u>22.8</u>	IV
3+ Rotten	<u>11.64</u>	<u>769</u>		<u>.30</u>	<u>1.0</u>	<u>1.08</u>	<u>70</u>	<u>41.4</u>	V
									3+ Sound & Rotten = IV + V = <u>64.2</u> VI
									Total = I + II + III + VI = <u>68.6</u> VII

	<u>Sum of 3+-inch diameters</u>	<u>Number of pieces</u>	<u>Average diameter</u>
Sound :	<u>33</u>	<u>4</u>	<u>8.25</u> in.
Rotten :	<u>37</u>	<u>2</u>	<u>18.5</u> in.
Sum of duff depths :	<u>4.5</u> in.		Sum of fuel depths : <u>40</u> in.
Number observations :	<u>4</u>		Number observations : <u>6</u>
Average duff depths :	<u>1.1</u> in.		Average fuel depths : <u>6.7</u> in.

Figure 13.--Computation summary sheet. The input values are from figure 12.

2. Total the number of intersections (n) over all sample points for each of the 0- to 0.25-inch, 0.25- to 1-inch, and 1- to 3-inch size classes.<sup>3/</sup>

3. From table 2, enter the appropriate squared average diameters (d<sup>2</sup>) for each size class on the computation sheet. If species composition has been determined, calculate an average d<sup>2</sup> as:

$$d^2 = \frac{P_1 d^2_1 + P_2 d^2_2 + P_3 d^2_3}{P_1 + P_2 + P_3}$$

Where P<sub>1</sub>, P<sub>2</sub>, and P<sub>3</sub> are percentages for composition of the species recorded in Step 9 (page 9).

If several species are present and their composition unknown, the composite d<sup>2</sup> values can be used as approximate averages.

Table 2.--Squared average-quadratic-mean diameters for nonslash and slash ground fuels

Size class (inches)	Nonslash		Slash	
	Cover type <sup>1/</sup>	Average d <sup>2</sup>	Species <sup>1/</sup>	Average d <sup>2</sup>
		Inches <sup>2</sup>		Inches <sup>2</sup>
0 - 0.25	PP	0.0342	PP, LP	0.0248
	LP	.0201	L	.0149
	S, DF, AF, C	.0122	DF, GF, C, S	.0122
	L	.0149	Composite <sup>2/</sup>	.0151
	Composite	.0151		
0.25 - 1	LP	.344	PP, C	.317
	S, DF, AF, C	.304	DF, GF, LP, L, S	.278
	L, PP	.238	Composite	.289
	Composite	.289		
1 - 3	PP, AF	3.12	LP	3.50
	S, DF, C, LP	2.87	DF, PP, GF	2.83
	L	2.17	L, C, S	2.30
	Composite	2.76	Composite	2.76

<sup>1/</sup>PP=ponderosa pine (*Pinus ponderosa*); LP=lodgepole pine (*Pinus contorta*); S=Engelmann spruce (*Picea engelmannii*); DF=Douglas-fir (*Pseudotsuga menziesii*); L=western larch (*Larix occidentalis*); GF=grand fir (*Abies grandis*); C=western redcedar (*Thuja plicata*); AF=subalpine fir (*Abies lasiocarpa*).

<sup>2/</sup>All composite values are averages of nonslash and slash fuels with each cover type and species weighted equally.

<sup>3/</sup>For calculating standard errors of the estimate, the number of intersections (Step 2) and the sum of squared diameters (Step 7) must be recorded for each plot.

4. Determine specific gravity(s) of materials from known sources or from laboratory studies. Approximate specific gravities for conifers are:

Diameter class ( <i>inches</i> ):	0-0.25	0.25-1	1-3	3+Sound	3+Rotten
Specific gravity	: 0.48	0.48	0.40	0.40	0.30

Decay and variability in density make this variable difficult to handle with accuracy. More accurate estimates for large sound material can be obtained by using specific gravities from the USDA Forest Service (1955) *Wood Handbook*. Special studies, as shown in Appendix II, are needed to improve accuracy for the other particle categories.

5. For slash, determine the nonhorizontal angle correction factors (a) from table 3. For nonslash fuels, use the following correction factors based on a composite of western species:

0 to 3 inches:	1.13
3+ inches:	1.00

The correction factor adjusts weight estimates for the fact that all particles do not lie horizontally as assumed in the planar intersect theory.

Table 3.--Average secant of nonhorizontal particle angles for correcting orientation bias for slash

Size class ( <i>inches</i> )	Species <sup>1/</sup>	Average (a)	
		Fresh slash	1-year and older slash
0 to 0.25	PP	1.25	1.25
	Others	1.40	1.15
0.25 to 1	PP	1.25	1.25
	Others	1.13	1.13
1 to 3	PP	1.22	1.22
	Others	1.10	1.10
3+	All (an assumption)	1.00	1.00

<sup>1/</sup>PP=ponderosa pine; Others=based on data for Douglas-fir, lodgepole pine, Engelmann spruce, western redcedar, western larch, and grand fir.

6. Calculate the total length of sampling line (Nℓ) for each size class: Nℓ = number of sample points multiplied by length of sampling plane (feet).

7. For material 3 inches and larger, square the diameter of each intersected piece and sum the squared values ( $\sum d^2$ ) for all pieces in the sampled area.<sup>4/</sup> Compute

<sup>4/</sup>*Ibid.*

$\Sigma d^2$  separately for sound and rotten categories. To obtain weights or volumes for certain diameter ranges (3 to 9 inches, for example), compute  $\Sigma d^2$  for the specified range.

8. Calculate the sum of diameters for all intersected pieces 3 inches and larger (calculate sound and rotten materials separately).

9. Calculate the sum of all measurements for duff depth.

10. Calculate tons/acre, using formulas on the computation sheet (fig. 13).<sup>5/</sup> If desired, calculate volumes:

$$\text{Cubic feet per acre} = \frac{32.05 \times \text{tons per acre}}{\text{Specific gravity}}$$

11. Calculate average diameters of intersected pieces 3 inches and larger.

12. Calculate average fuel depth and duff depth as the sum of the depths divided by the number of measurements.

13. Appendix III shows how to calculate needle quantities in slash.

When inventorying large areas that hold many species it is practical to use composite values and approximations for diameters, specific gravities, and nonhorizontal corrections. For example, a timber management and downed-debris inventory in the Northern Region of the USDA Forest Service utilizes composite average diameters, composite average nonhorizontal correction factors, and best approximations for specific gravities.

For the Northern Region inventory, the formulas in figure 13 simplify to:

1. 0- to 0.25-inch size class:  $w = 0.09533 \text{ nc/N}\ell$
2. 0.25- to 1-inch size class:  $w = 1.825 \text{ nc/N}\ell$
3. 1- to 3-inch size class :  $w = 14.52 \text{ nc/N}\ell$
4. 3+-inch sound :  $w = 4.656 \Sigma d^2 c / \text{N}\ell$
5. 3+-inch rotten :  $w = 3.492 \Sigma d^2 c / \text{N}\ell$

where:

$w = \text{weight, tons/acre.}$

---

<sup>5/</sup>The formulas incorporate an insignificant bias because  $n$ ,  $\Sigma d^2$ , and  $c$  are totaled separately. Summing  $n \times c$  or  $\Sigma d^2 \times c$  over all plots would eliminate the biases; however, this is unnecessarily troublesome.



# FURTHER APPLICATIONS

If only debris larger than 3 or 4 inches in diameter is to be inventoried, the line intersect technique described by Howard and Ward (1972) and Bailey (1969) might be more appropriate than the planar intersect method, especially in logging slash. The line intersect method employs a few long sampling planes; the planar intersect method employs many small sampling planes. If debris both greater than and less than 3 or 4 inches in diameter must be inventoried, the planar intersect technique is more efficient. The planar intersect technique can also be coordinated with other measurements of vegetation taken on plots (for example, an inventory of timber volume).

The procedures in this Handbook can be applied to downed debris in areas other than the western United States by assuming or measuring average diameters for the three size classes of particles. Average diameters have been determined for red pine (*Pinus resinosa*), jack pine (*Pinus banksiana*), and oak (*Quercus* spp.) (Brown and Roussopoulos 1974). A convenient method for estimating slash weights of several Lake States tree species has been reported by Roussopoulos and Johnson (1973).

If fire behavior is to be mathematically modeled using models such as Rothermel's (1972), weights of other fine fuels such as needle litter, dead grass, and dead forbs also should be determined by sampling or by extrapolating from existing information. Sampling for quantities of grass, forbs, and litter requires methods other than the planar intersect technique (USDA Forest Service 1959; Brown 1966; Hutchings and Schmutz 1969).

Because practical methods of inventory have been lacking in the past, accumulations of downed fuel and debris have been described in vague terms such as "light," "medium," and "heavy." Using the simple field procedures in this Handbook, weight and volume of downed woody material can be inventoried to provide an objective basis for managing debris.

# LITERATURE CITED

- Bailey, G. R.  
1969. An evaluation of the line-intersect method of assessing logging residue. Can. Dep. Fish. & For., For. Prod. Lab. Inf. Rep. VP-X-23, 41 p.
- Beaufait, William R., Michael A. Marsden, and Rodney A. Norum  
1974. Inventory of slash fuels using 3P subsampling. USDA For. Serv. Gen. Tech. Rep. INT-13, 17 p., illus.
- Brown, J. K.  
1966. Forest floor fuels in red and jack pine stands. USDA For. Serv. Res. Note NC-9, 3 p.
- Brown, James K.  
1971. A planar intersect method for sampling fuel volume and surface area. For. Sci. 17(1):96-102, illus.
- Brown, James K.  
1972. Field test of a rate-of-fire-spread model in slash fuels. USDA For. Serv. Res. Pap. INT-116, 24 p., illus.
- Brown, James K., and Peter J. Roussopoulos  
Eliminating biases in the planar intersect method for sampling small fuel volumes. For. Sci. (In press.)
- Deeming, John E., James W. Lancaster, Michael A. Fosberg, R. William Furman, and Mark J. Schroeder  
1972. National fire-danger rating system. USDA For. Serv. Res. Pap. RM-84, 165 p.
- Fahnestock, G. R.  
1960. Logging slash flammability. USDA For. Serv. Res. Pap. INT-58, 67 p., illus.
- Fosberg, Michael A.  
1970. Drying rates of heartwood below fiber saturation. For. Sci. 16(1): 57-63, illus.
- Howard, James O., and Franklin R. Ward  
1972. Measurement of logging residue--alternative applications of the line intersect method. USDA For. Serv. Res. Note PNW-183, 8 p.
- Hutchings, S. S., and J. E. Schmutz  
1969. A field test of the relative-weight-estimate method for determining herbage production. J. Range Manage. 22:408-411.
- Roussopoulos, P. J., and V. J. Johnson  
1973. Estimating slash fuel loading for several Lake States tree species. USDA For. Serv. Res. Pap. NC-88, 8 p.
- Rothermel, R. C.  
1972. A mathematical model for predicting fire spread in wildland fuels. USDA For. Serv. Res. Pap. INT-115, 40 p., illus.
- Van Wagner, C. E.  
1968. The line intersect method in forest fuel sampling. For. Sci. 14(1): 20-26, illus.
- USDA Forest Service  
1955. Wood Handbook No. 72, 528 p. For. Prod. Lab., Madison, Wis.
- USDA Forest Service  
1959. Techniques and methods of measuring understory vegetation. Southern and Southeast For. Exp. Stn. Symp. Proc., 174 p.

# APPENDIX I

## Sampling Intensities

### NUMBER AND SIZE OF SAMPLING PLANES

Sampling precision can be controlled by altering the number of plots and length of sampling planes. As a general rule, the more downed material on an area, the fewer the number and shorter the length of sampling planes required to achieve a given level of precision. Figure 14, based on average sampling variation for number of intersections of 0- to 1-inch and 1- to 3-inch particles, can help in choosing number of plots and length of sampling planes. The data for figure 14 are from many stands of varying composition and downed debris accumulations in northern Idaho and western Montana. Curves for all material under 3 inches in diameter would fall between those for the 0- to 1-inch and 1- to 3-inch classes.

Percent errors of 20 percent or less are probably adequate levels of precision for assessing most fuel problems. Percent error is the standard error of the estimate divided by the mean estimate and expressed as a percentage. More precision, such as percent errors of 10 to 15 percent, may be desirable for evaluating utilization potential of downed woody material.

Precision is maximized using a different length of sampling plane for each size class. However, considering both field effort and precision, it is more efficient to use the same plane length for sampling the 0- to 0.25- and 0.25- to 1-inch classes. The following suggestions will help determine the most efficient number and length of sampling planes for a given area:

1. Record data from about 20 sampling planes in an area and calculate the variation for guiding further sampling.

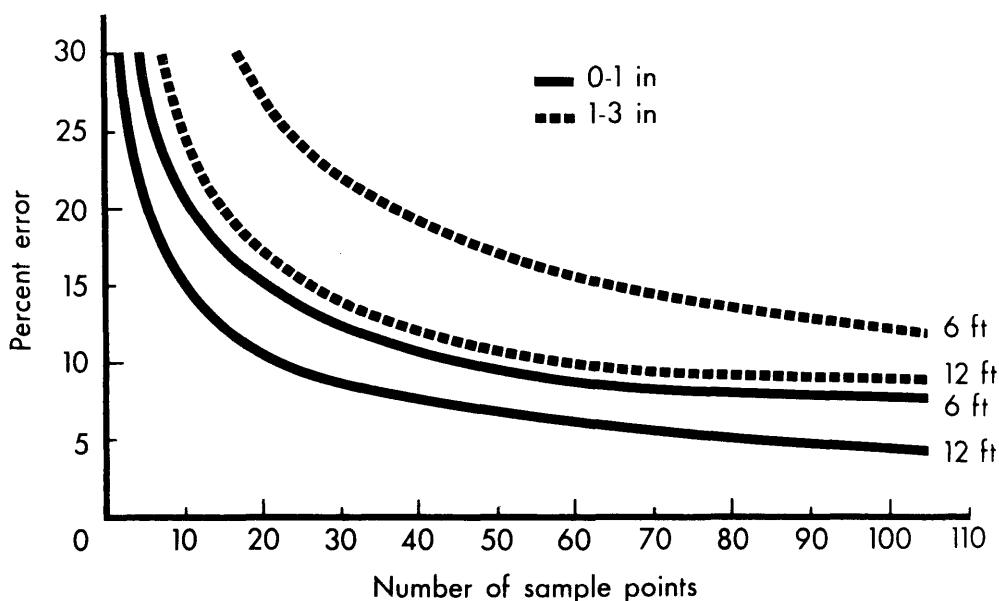

Figure 14.--Percent errors for number of particle intersections along 6- and 12-foot-length sampling planes related to number of sample points for quantities of light slash and nonslash. Percent error is 100X (standard error of the estimate divided by the mean estimate).

2. For material larger than 3 inches in diameter, the sampling plane should be long enough so that on the average at least one intersection occurs with three-fourths or more of the planes. A large sampling variance results when many zeros are recorded for intersections. In areas where very little downed material exists, sampling planes should actually be one to several hundred feet long to provide respectable precision. Where many sampling planes have zero entries, other methods such as measurement of length and diameter of all downed pieces may be the most efficient method of inventory.

3. The number and length of sampling planes should be chosen so that for a piece size of interest, such as material over 3 inches in diameter, at least 35 to 50 intersections occur over an entire sampled area.

*SAMPLING PRECISION FOR DEPTH MEASUREMENTS*

To achieve percent errors of 15 and 20 percent using two-stage sampling, the most efficient number of secondary sampling units appears to be three for fuel depth and two for duff depth (fig. 15).

The data for figure 15 represent average variation from sampling a wide variety of forest and downed fuel conditions in northern Idaho and western Montana. Several thousand measurements were taken using two secondary sample points for duff depth and three secondary sample points for fuel depth. Vegetation qualifying for fuel depth measurements included all dead downed woody material and dead brush, grass, and forbs. The data were subjected to analysis of variance for two-stage sampling.

The number of sample plots required to attain a given level of precision varies considerably among different areas. For choosing sampling intensities for specific areas the number of primary sample points in figure 15 could be adjusted up or down considerably, depending on homogeneity of the dead vegetation strata.

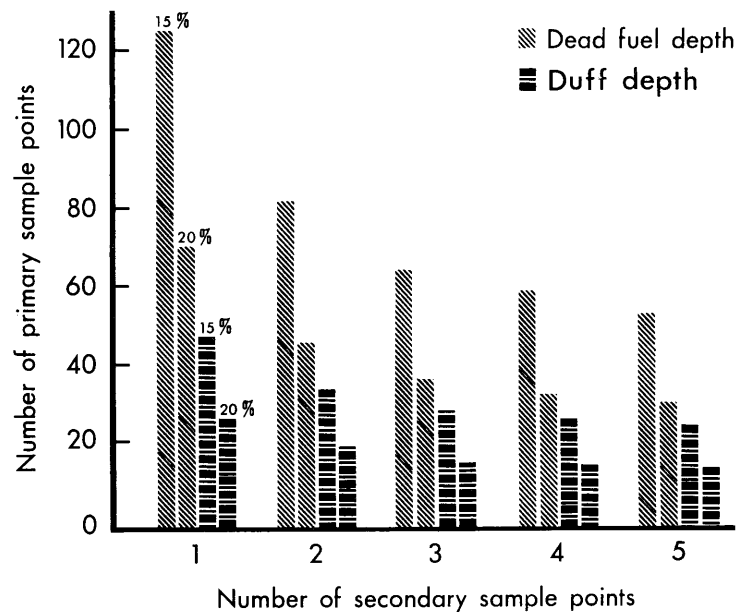

Figure 15.--Number of primary and secondary points needed to achieve percent errors of 15 and 20 percent for fuel depth and duff depth.

# APPENDIX II

## Specific Gravities of Sound Material

The specific gravities in table 4 are based on oven-dry weight and air-dry volume and can be used for calculation of loadings.

Table 4.--*Specific gravity of woody twigs and branches with bark attached*

Species	Diameter size class (cm)				
	$\frac{1}{0} - 1$	$\frac{1}{1} - 10$	$\frac{2}{0} - 1$	$\frac{2}{1} - 3$	$\frac{2}{3} - 5$
Ponderosa pine	0.41	0.51	0.57	0.53	0.49
Douglas-fir	.55	.43	.56	.56	.52
Western larch	.46	.55			
Lodgepole pine	.49	.41			
Engelmann spruce	.34	.34			
Subalpine fir	.41	.40			
Western redcedar	.48	.33			

<sup>1/</sup> William R. Beaufait and Charles E. Hardy. Fire quantification for silvicultural use. USDA For. Serv., Intermt. For. & Range Exp. Stn. (In preparation.)

<sup>2/</sup> Brown (1972).

# APPENDIX III

## Calculating Needle Quantities

Weight of needles can be determined by multiplying ratios of needle-to-branchwood weights (table 5) times estimated branchwood weight. The estimates in table 5 are for branches having all needles attached. The data are based on estimates of needles and branchwood from total living crowns for trees between 2 and 30 inches d.b.h.

Table 5.--*Foliage-to-branchwood ratios based on oven-dry weight*

Species	Diameter of branches		No. trees sampled
	0- to 0.25-inch	0- to 1-inch	
Western larch	0.70	0.43	13
Ponderosa pine	14.10	.98	14
Western white pine	3.30	1.02	5
Douglas-fir	2.19	.82	9
Western hemlock	1.90	.80	17
Engelmann spruce	2.38	1.34	4
Western redcedar	5.00	1.45	13
Lodgepole pine <sup>1/</sup>	1.34	.31	3
Grand fir <sup>1/</sup>	2.52	1.00	3

<sup>1/</sup> Data by Fahnestock (1960).

Headquarters for the Intermountain Forest and Range Experiment Station are in Ogden, Utah. Field Research Work Units are maintained in:

Boise, Idaho

Bozeman, Montana (in cooperation with Montana State University)

Logan, Utah (in cooperation with Utah State University)

Missoula, Montana (in cooperation with University of Montana)

Moscow, Idaho (in cooperation with the University of Idaho)

Provo, Utah (in cooperation with Brigham Young University)

Reno, Nevada (in cooperation with the University of Nevada)

